

E 2039

0596.00/10 De 9. DEZ. 1988

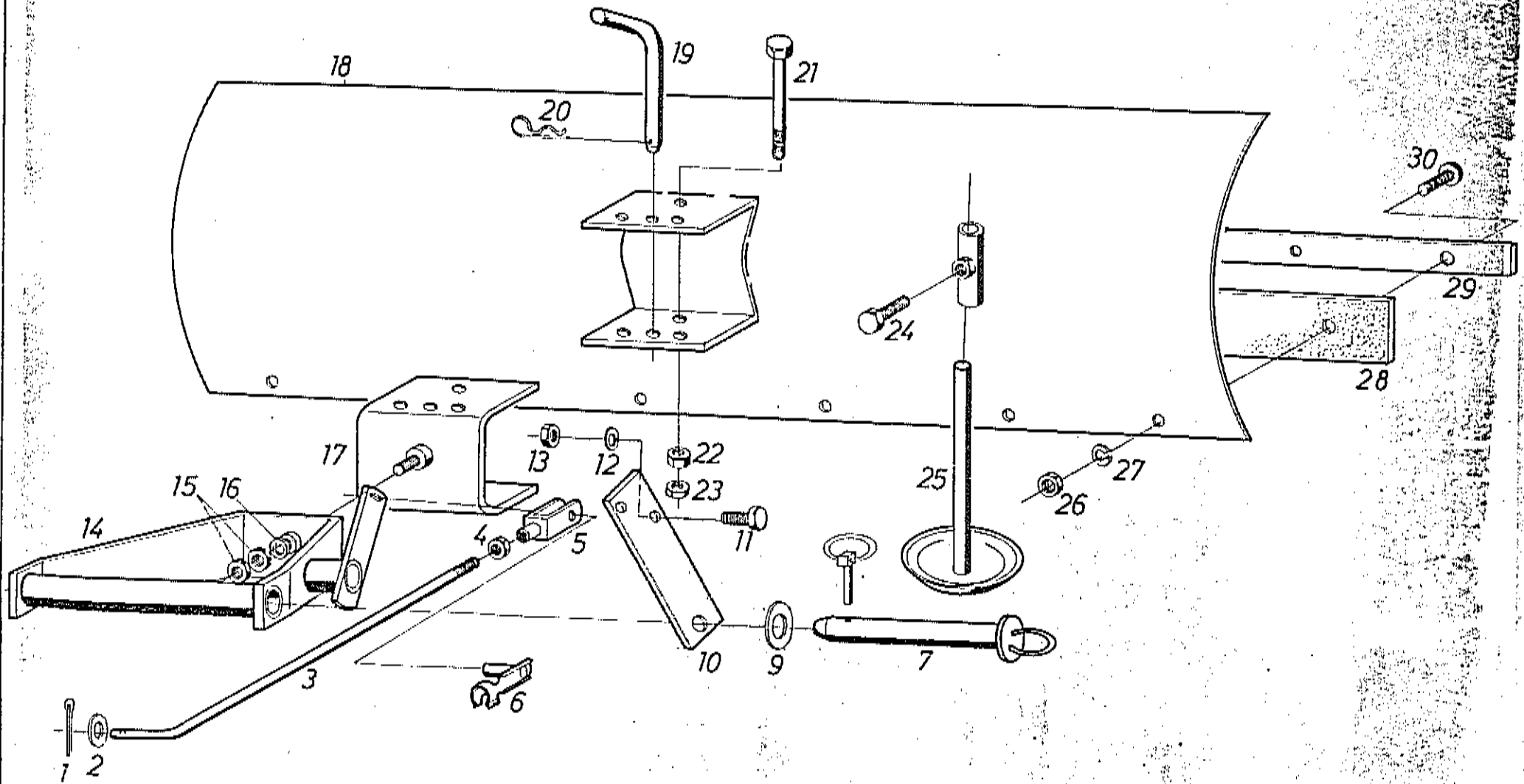

D1

Bild- Fig No.	Teile- No. pieces Parts-Number	Bezeichnung	Désignation	Description	Norm-Bez / Fren No. d la norme / Ref Fourn Standard Descr / Part -No not Gubtr	Stück- Nbr Nbr.
-		Geräteträger Art. Nr. 0565	Support frontal Nr. de code 0565 comprenant les	Front tool support Art. Nr. 0565 consisting		
-		bestehend aus den Teilen 1 bis 13	pieces 1 à 13	of parts 1 to 13		
1	24.6488.40	Splint	Goupille	Pin	3x20 DIN 94	1
2	24.6484.22	Scheibe	Rondelle	Washer	10 DIN 1440	1
3	26.66.025	Aushebestange	Tige de relevage	Lift rod		1
4	24.1421.22	Sechskantmutter	Ecrou	Nut	M 10 DIN 934	1
5	28.6218.22	Gabelkopf	Fourchette	Yoke		1
6	25.9425.18	ES-Bolzen	Axe	Bolt	10x40 ESN 01	1
7	26.66.812	Steckbolzen vollst.	Poignee	Clevis		1
8	00.17.034	Klappsplint	Goupille à clapet	Pin		1
9	24.6484.32	Scheibe	Rondelle	Washer	20 DIN 1440	1
10	26.66.019	Tragarm	Support	Bracket		2
11	21.1441.92	Sechskantschraube	Vis	Screw	M 10x35 DIN 933	4
12	24.8175.22	Federring	Rondelle Grower	L-washer	B 10 DIN 127	4
13	24.1421.22	Sechskantmutter	Ecrou	Nut	M 10 DIN 934	4
-		Räumschild Art. Nr. 0596	Lameniveleuse Nr. de code	Dozerblade Art. Nr. 0596		
-		bestehend aus den Teilen 14 bis 30	0596 comprenant les pieces 14 à 30	consisting of parts 14 to 30		
14	26.68.810	Tragrahmen vollst.	Ens. Support	Frame - support		1
15	24.1423.35	Sechskantmutter	Ecrou	Nut	M 20 DIN 936	2
16	24.6481.35	Scheibe	Rondelle	Washer	21 DIN 125	1
17	26.68.811	Verstellbügel vollst.	Support réglable	Adjusting bracket		1
18	26.68.800	Räumschild vollst.	Lame niveleuse	Dozer blade		1

D2

Bild Fig No.	Teile-Nr No. pieces Parts-Number	Bezeichnung	Désignation	Description	Norm-Bez / Fremd No d la norme / Ext. Fourn Standard Descr / Part -No not Gufbr	Stück Nbr Nbr.
19	26.68.019	Steckbolzen	Poignee	Bolt		1
20	701.99.031	Ziehsplint	Goupille	Pin		1
21	21.1444.74	Sechskantschraube	Vis	Screw	M 16x 160 DIN93	1
22	24.1421.31	Sechskantmutter	Ecrou	Nut	M 16 DIN 934	1
23	24.1423.31	Sechskantmutter	Ecrou	Nut	M 16 DIN 936	1
24	21.1442.10	Sechskantschraube	Vis	Screw	M 8x25 DIN 933	2
25	73.68.814	Tellerschleifsohle voll	Patin	Slide-sole		2
26	24.1421.18	Sechskantmutter	Ecrou	Nut	M 8 DIN 934	5
27	24.8195.18	Federring	Rondelle Grower	L-washer	B 8 DIN 127	5
28	26.68.021	Gummileiste	Plaque d'usure	Rubber skirt		1
29	26.68.022	Halteblech	Fixation plaque	Skirt bracket		1
30	22.3417.28	Flächrundschrabe	Vis	Screw	M 8x30 DIN 603	5

D3