

E2027

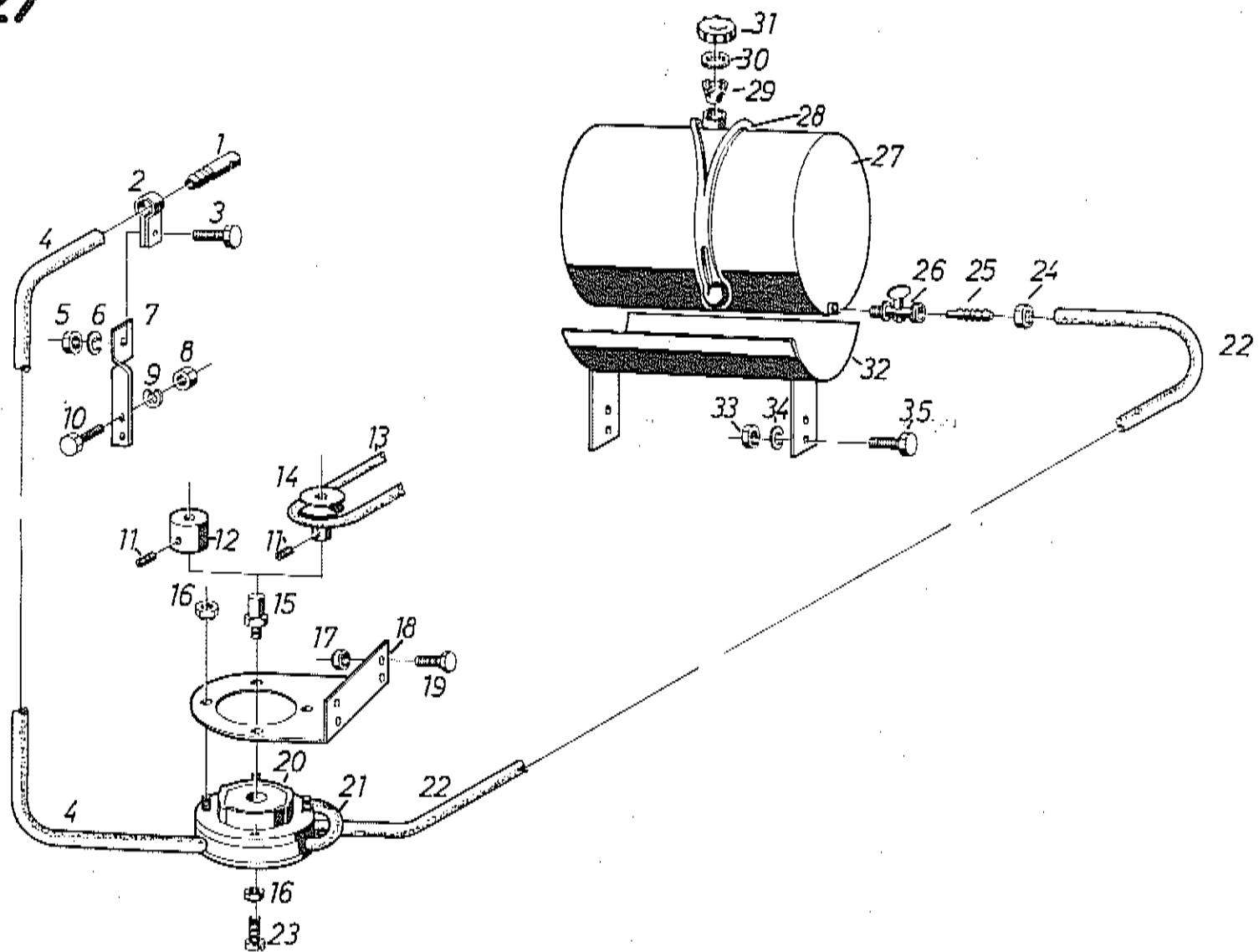

Bild Fig. No.	Teile Nummer No. pièce Parts No.	Teile Bezeichnung	Désignation	Description	Norm-Bez. oder Fremdtelle-Nr. No. de la norme ou référence fournisseur	Stck Nbr		
1	86.66.053	Düse	Gicleur	Nozzle		1		
2	00.70.281	Rohrschelle	Collier	Clamp		1		
3	21.1141.46	Sechskantschraube	Vis	Screw	M6x16 DIN933	1		
4	00.23.434	Schlauch	Tuyau	Hose	8/2 x 970	1		
5	24.1421.14	Sechskantmutter	Ecrou	Nut	M 6 DIN 934	1		
6	24.8195.14	Federring	Rondelle Grower	Spring washer	B 6 DIN 127	1		
7	86.66.055	Düsenträger	Support de Gicleur	Bracket		1		
8	24.1421.14	Sechskantmutter	Ecrou	Nut	M 6 DIN 934	2		
9	24.8195.14	Federring	Rondelle Grower	Spring washer	B 6 DIN 127	2		
10	21.1441.44	Sechskantschraube	Vis	Screw	M6x10 DIN 933	2		
11	23.3411.14	Gewindestift	Goujon	Stud	M4x10 DIN533	2		
12	26.66.026	Lauffrolle	Rouleau	Roller		1		
13	00.75.674	Rundriemen	Courroie	Belt		1		
14	86.66.054	Kettenscheibe	Poulie	Pulley		1		
15	73.65.068	Zwischenstück	Axe	Shaft		1		
16	24.1426.06	Sechskantmutter	Ecrou	Nut	M 3 DIN 985	4		
17	24.1426.12	Sechskantmutter	Ecrou	Nut	M 5 DIN 985	2		
18	73.65.069	Pumpenträger	Support de pompe	Pump support		1		
19	21.1441.26	Sechskantschraube	Vis	Screw	M5x16 DIN933	2		
20	99.01.822	Pumpe	Pompe	Pump		1		
21	00.23.437	Schlauch	Tuyau	Hose	8/2 x 130	1		
22	00.23.433	Schlauch	Tuyau	Hose	8/2 x 600	1		
23	21.6421.32	Zylinderschraube	Vis	Screw	AM3x35 DIN84	2		
24	91.15.054	Überwurfmutter	Ecrou chapeau	Cap nut		1		
25	91.15.053	Aufstecknippel	Embout	Nipple		1		
26	91.15.052	Absperrhahn	Robinat	Valve		1		
27	91.15.281	Tank vollst. = 24.15.050	Réservoir ens.	Tank assy.		1		
28	00.37.052	Spannband	Attache	Fastening strap		1		
29	91.15.049	Siebeinsatz	Filtre	Filter		1		
30	91.15.048	Dichtung	Joint	Gasket		1		
31	91.15.047	Tankverschluss	Capuchon de réservoir	Tank cap		1		
32	86.66.830	Tankträger vollst.	Support de réservoir ens.	Tank support		1		
33	24.1421.14	Sechskantmutter	Ecrou	Nut	M 6 DIN 934	4		
34	24.8195.14	Federring	Rondelle Grower	Spring washer	B 6 DIN 127	4		
35	21.1441.48	Sechskantschraube	Vis	Screw	M6x20 DIN933	4		
		Wassersprengeinrichtung für Kehrmaschine	Dispositif d'arrosage pour balai frontal	Sprinkler for Frontsweeper	E 2027 / 75			